

Obstacle Detection and Warning System for Hill Roads to Minimize Accidents

Muskan Nasir Dange, Sayli Jaywant Yadav, Rohit Arjun Jamdade,
Sakshi Sharad Sawant, Shraddha Nitin Jamdade, Sangram Bajrang

Koli, Mr. Kuldeep B. Pawar

Department of Electrical Engineering
Shree Santkrupa Institute of Technology

Abstract- This paper presents a safety-oriented system designed specifically for accident prevention in ghat (hilly) road sections. The primary objective of the proposed system is to reduce accidents caused by limited visibility on sharp curves and narrow roads, where drivers are unable to detect oncoming vehicles from the opposite direction. High vehicle speed and lack of real-time information further increase the risk of collisions in such regions. To address these challenges, an embedded system based on the ATmega328 (or 8051) microcontroller is proposed. The system integrates multiple sensors, including IR or ultrasonic sensors for vehicle detection and a piezoelectric sensor for landslide detection. Additional components such as LED indicators, an LCD display, a GSM module, and a buzzer are incorporated for alert generation and communication. When a vehicle is detected at one end of the road, the system activates a warning signal using a flashing red light and alerts drivers, while a green signal indicates that the road is clear. In the event of a landslide, the system automatically triggers an early warning mechanism and closes safety gates to prevent vehicle movement, thereby reducing the risk of accidents.

Keywords- Obstacle Detection, Hill Road Safety, Accident Prevention System, Intelligent Transportation System

I. INTRODUCTION

Road accidents have become one of the leading causes of fatalities worldwide, with factors such as reckless driving, signal violations, driving under the influence, and lack of experience contributing significantly to the problem. In ghat sections, the risk of accidents is even higher due to sharp curves, steep slopes, and limited road width. These conditions often restrict visibility, making it difficult for drivers to detect vehicles approaching from the opposite direction. As a result, drivers are forced to rely on assumptions while navigating turns, which can lead to severe accidents, injuries, or even loss of life [2]. India reports one of the highest rates of road accidents globally, making road safety a critical concern. Although modern navigation tools such as digital maps assist in route planning, they fail to provide real-time information about road complexity, visibility conditions, or potential hazards in hilly regions. Environmental factors such as fog, smog, and overgrown vegetation during the rainy

season further reduce visibility, increasing the likelihood of accidents.

Traffic accidents continue to be a major source of damage and loss despite increased awareness and regulations such as adherence to traffic rules, speed limits, and loading guidelines. Drivers often neglect warning signs such as "School Zone," "Hospital Area," or "No Horn Zone," and may fail to notice curves, speed breakers, or obstacles, thereby putting lives at risk. In addition to vehicular hazards, natural events such as landslides pose a significant threat in hilly regions. Landslides, defined as the downward movement of soil, rocks, and debris under the influence of gravity, can occur suddenly and cause catastrophic damage. Several countries, including India, have experienced severe landslides in recent years, leading to substantial loss of life and property. To mitigate such risks, the implementation of early warning systems is essential. Continuous monitoring of environmental conditions and slope movements can provide timely alerts, allowing drivers and local authorities to take preventive action. Therefore, the

development of an intelligent, sensor-based accident prevention system is crucial to improve safety, reduce fatalities, and enhance transportation reliability in ghat sections.

II. LITERATURE REVIEW

Blind spot detection systems have become an essential component of modern intelligent transportation systems, particularly in environments where driver visibility is limited such as hilly and curved roads. Radar-based blind spot detection using Frequency Modulated Continuous Wave (FMCW) technology has been widely explored due to its ability to detect objects reliably under adverse environmental conditions such as fog, rain, and low visibility. These systems use advanced signal processing and tracking algorithms to improve detection accuracy and reliability in real-time vehicular environments [1]. Recent studies emphasize the importance of millimeter-wave radar sensors in automotive blind spot detection, as they provide long-range detection capabilities (up to 120 meters) and velocity tracking of moving vehicles. These systems are widely used in advanced driver assistance systems (ADAS) to enhance safety by continuously monitoring areas not visible to the driver [2]. Sensor fusion techniques combining radar and ultrasonic sensors have been proposed to improve detection accuracy and reduce false positives. Ultrasonic sensors provide precise short-range detection, while radar sensors offer better performance for long-range and high-speed object tracking, making the combination highly effective for blind spot monitoring [3].

Ultrasonic sensor-based blind spot detection systems have also been developed as low-cost alternatives, particularly for small vehicles and retrofitting existing vehicles. These systems measure distance using time-of-flight principles and provide real-time alerts to drivers when obstacles enter predefined threshold zones [4]. Microcontroller-based embedded systems play a critical role in blind spot detection by processing sensor data and triggering alerts. Systems using Arduino or ATmega-based controllers are widely implemented due to their low cost, flexibility, and ability to integrate

multiple sensors efficiently [5]. Camera-based blind spot detection systems have also been explored, where image processing techniques such as optical flow are used to detect moving objects in blind zones. These systems analyze pixel motion to identify vehicles entering dangerous zones and generate warning signals [6].

Recent advancements in artificial intelligence have enabled the use of deep learning models such as convolutional neural networks (CNNs) for blind spot detection. These models improve detection accuracy by extracting high-level features from images and combining multiple data sources, reducing false detection rates significantly [7]. Edge computing and IoT-based blind spot detection systems have been introduced to enable real-time data processing and communication. These systems use embedded devices such as Arduino and NodeMCU to collect sensor data and transmit it to cloud or fog computing platforms for analysis and decision-making [8]. In addition, blind spot detection systems have been implemented in buses and heavy vehicles using multi-sensor configurations. These systems address the increased blind spot areas in large vehicles and provide real-time alerts to drivers to prevent collisions [9]. Vision-based systems using multiple cameras have also been proposed to enhance blind spot monitoring. These systems combine front and rear imaging devices to analyze optical flow and detect objects in blind zones, providing visual and auditory alerts to drivers [10].

Research has also focused on improving radar target detection using advanced techniques such as reconfigurable intelligent surfaces (RIS), which enhance signal reflection and improve detection accuracy in complex environments [11]. Deep learning-based blind spot detection approaches have demonstrated high performance in detecting vehicles in complex traffic conditions. These systems integrate multiple neural networks to improve feature extraction and achieve lower false detection rates [12]. The integration of GSM communication modules in embedded systems enables real-time alert transmission in remote areas where internet connectivity is limited. These systems can send SMS

alerts to drivers or control centers, making them suitable for hilly and rural road conditions [13].

Energy-efficient designs using solar power have been proposed to ensure continuous operation of blind spot detection systems in remote locations. These systems incorporate power management modules to regulate voltage and monitor energy consumption [14]. Overall, the literature indicates that multi-sensor fusion, embedded processing, wireless communication, and energy-efficient design are key factors in developing reliable blind spot detection systems. These advancements are particularly relevant for hilly road environments, where visibility constraints and challenging terrain require robust and adaptive safety solutions [15].

III. METHODOLOGY

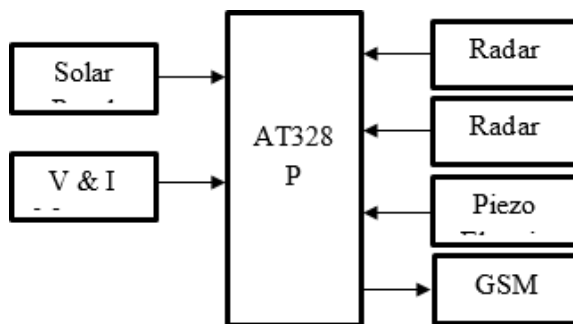

Fig1. Block Diagram of Proposed Work

The given block diagram represents a Blind Spot Detection System for hilly roads, designed using an embedded system centered around the ATmega328P (AT328P) microcontroller. The system integrates multiple sensing, processing, power, and communication modules to detect obstacles or vehicles in blind zones—especially critical in curved and mountainous terrains where visibility is limited. At the input side, the solar panel DC–DC unit provides a sustainable and regulated power supply to the system. Since hilly areas may lack consistent electrical infrastructure, solar energy ensures continuous operation. The DC–DC converter stabilizes the voltage to levels suitable for electronic components, improving efficiency and reliability. Alongside this, a voltage and current (V & I) measurement module monitors system health, ensuring proper energy utilization and enabling fault

detection such as battery drain or overvoltage conditions.

The core of the system is the ATmega328P microcontroller, which acts as the central processing unit. It collects data from multiple sensors, processes the signals, and makes decisions based on programmed logic. This microcontroller is widely used in embedded systems due to its low power consumption, ease of programming, and compatibility with sensor modules. On the sensing side, the system employs multiple radar sensors strategically placed to monitor blind spots on both sides of the road. Radar sensors are particularly suitable for hilly environments because they can detect objects even in fog, rain, or low visibility conditions. These sensors continuously emit radio waves and analyze the reflected signals to determine the presence, distance, and movement of vehicles or obstacles. Using more than one radar sensor improves coverage and reduces detection errors in curved roads.

Additionally, a piezoelectric sensor is integrated for vibration or impact detection. This can be used to detect sudden movements, landslides, or approaching vehicles through vibration patterns, enhancing the system's responsiveness in rough terrains. It can also act as an alert mechanism by generating sound signals when a hazard is detected. For communication, the system uses a GSM SIM800L module, which enables wireless transmission of alerts or notifications. When the system detects a vehicle in the blind spot or a potential collision risk, it can send SMS alerts or notifications to nearby drivers, control stations, or warning systems. This makes the system suitable for remote areas where internet connectivity is limited but GSM networks are available.

Overall, the system works in a continuous loop: sensors detect environmental conditions → the microcontroller processes the data → decisions are made → alerts are generated via buzzer or GSM communication. This integrated approach ensures real-time blind spot detection, improved safety, and reduced accident risks in hilly road conditions.

IV. CONCLUSION

The proposed blind spot detection and accident prevention system for ghat (hilly) roads provides an effective and practical solution to address the critical issue of limited visibility on curved and narrow road sections. By integrating multiple sensors such as IR/ultrasonic sensors for vehicle detection and a piezoelectric sensor for landslide monitoring with a microcontroller-based processing unit, the system is capable of identifying potential hazards in real time. The use of visual indicators, buzzer alerts, and GSM communication ensures that timely warnings are delivered to drivers, thereby reducing the chances of collisions. Additionally, the incorporation of an automated gate mechanism during landslide events further enhances safety by preventing vehicle entry into dangerous zones.

REFERENCES

1. W. Kim, H. Yang, and J. Kim, "Blind Spot Detection Radar System Design for Safe Driving of Smart Vehicles," *Applied Sciences*, vol. 13, no. 10, 2023.
2. Texas Instruments, "Entry-Level Blind Spot Detection Reference Design Using mmWave Radar," 2024.
3. "Motorcycle Blind Spot Detection System Using Radar and Ultrasonic Sensors," *IJARCCCE*, 2025.
4. "Smart Blind Spot Detection System Using Ultrasonic Sensors," *ACR Journal*, 2024.
5. S. Khadijah, "Car Driver Assisted Blind Spot Detection System," *Univ. Malaysia Pahang*, 2012.
6. S. Yu and M. Wu, "Position and Vector Detection of Blind Spot Motion with Optical Flow," *arXiv*, 2016.
7. M. Muzammel et al., "Blind-Spot Collision Detection Using Multi Deep CNN Architecture," *arXiv*, 2022.
8. A. Mukhopadhyay, "Edge-Based Blind Spot Avoidance and Speed Monitoring System," *Procedia Computer Science*, 2024.
9. "Sensor-Based Blind Spot Detection System for Buses," *Makerere University*, 2022.
10. "Blind Spot Detection System and Method," *US Patent US8004425B2*, 2011.
11. S. Buzzi et al., "Radar Target Detection Aided by Reconfigurable Intelligent Surfaces," *arXiv*, 2021.
12. A. Bordone et al., "Deep Learning-Based Radar Image Processing Using Blind-Spot Networks," *arXiv*, 2020.
13. GSM-Based Embedded Alert Systems for Remote Monitoring Applications, *ResearchGate*, 2018.
14. Renewable Energy-Based Embedded Systems for Remote Monitoring, *IEEE Access*, 2021.
15. Overview of Blind Spot Monitoring Systems in Intelligent Vehicles, *Automotive Safety Review*, 2023.