

Notes2Card: AI-Based Study Content Generation

Professor S.P.Gunjaj, Professor C.P.Lachake, Dandale, Deshmukh
Ashutosh, Vaishnavi, Gawai Yash, Pal Babita

Department of Computer Engineering, SKN Sinhgad Institute of Technology & Science, Lonavala,
Maharashtra.

Abstract- The rapid growth of digital learning has increased the need for tools that can convert broad topics into structured and revision-friendly study material. This project presents Notes2Card, an AI-assisted web application that helps learners generate complete study resources from a user-provided topic and learning purpose. The system creates a course outline with chapter-wise structure, generates detailed chapter notes, and supports additional study formats such as flashcards and quizzes for active recall and self-assessment. Notes2Card is built using Next.js for the application layer, Clerk for user authentication, Neon PostgreSQL with Drizzle ORM for data persistence, Gemini API for AI-based content generation, Inngest for asynchronous background processing, and Stripe for subscription-based membership management. The platform follows a modular architecture with separate APIs for course creation, content retrieval, study-type generation, user status, and payment of workflows. It also includes robust AI error classification and status tracking to improve reliability during content generation. The implemented system supports both free-tier and paid-tier users, with server-side enforcement of usage limits for non-members. Experimental usage of the application demonstrates that the platform can reduce the manual effort required to prepare structured study material while improving accessibility and consistency of learning content. The project validates the practical use of AI and event-driven processing in building scalable educational tools.

Keywords- AI study tool, Study notes generator, Flashcard maker AI, Notes to flashcards, AI flashcard generator, Smart study assistant

I. INTRODUCTION

The increasing availability of digital educational resources has improved access to knowledge, but it has also created a practical problem for learners: converting broad topics into structured, exam-ready material requires significant time and effort. Students often spend more time organizing notes, identifying key points, and preparing revision content than learning the concepts. This challenge becomes more serious when learners need multiple study formats such as concise notes, recall cards, and self-assessment quizzes.

To address this issue, this project presents Notes2Card, an AI-assisted study material generation platform that transforms user input into organized learning content. A learner provides a topic, study purpose, and difficulty level, and the system generates a chapter-wise course outline, detailed notes, flashcards, and quizzes. By combining content generation and revision tools in one workflow, the application supports both concept understanding and active recall.

The system is implemented as a full-stack web application using Next.js, Clerk authentication, Neon PostgreSQL with Drizzle ORM, Gemini API for AI content generation, Inngest for asynchronous background jobs, and Stripe for subscription management. The architecture is modular, with separate APIs for course creation, study-type generation, retrieval, membership status, and payments. The

implementation also includes practical safeguards such as server-side free-tier limits, content-generation status tracking, and AI error classification to handle unreliable external AI responses. This project focuses on delivering implemented, production-relevant functionality rather than theoretical features. The outcome demonstrates that AI can be integrated into a scalable educational workflow to reduce manual preparation effort and provide learners with faster, structured, and interactive study support.

II. LITERATURE SURVEY

1. AI in Education and Personalized Learning

Artificial Intelligence in Education (AIED) has progressed significantly from traditional rule-based tutoring systems to modern adaptive and data-driven learning platforms. Earlier studies on mastery learning and one-to-one tutoring demonstrated that personalized instruction can greatly improve student performance and understanding [1], [2]. Later research on intelligent tutoring systems showed that automated educational support can, in specific domains, provide results comparable to human tutoring [3].

These developments highlight the growing importance of AI-powered learning systems that can adjust study pace, content depth, and learning style according to individual student needs.

2. Generative AI for Study Content Creation

Recent advancements in Large Language Models (LLMs) have enabled the automatic generation of educational content such as summaries, notes, explanations, and structured study materials [4], [5]. In higher education, such tools are increasingly being explored to reduce the time spent on repetitive academic tasks while improving accessibility and learning efficiency [6].

However, studies also identify concerns such as hallucinated content, misleading responses, and factual inaccuracies. Therefore, effective prompt engineering and output validation are essential for ensuring reliability [7]. This supports the use of controlled AI systems where prompts are designed around specific topics, chapters, and expected output formats.

3. Automatic Question and Quiz Generation

Automatic question generation has been widely researched as an effective method for formative assessment and student practice [8]. Earlier Natural Language Processing (NLP) methods relied on predefined templates, whereas transformer-based models have significantly improved question relevance, grammar, and contextual quality.

Quiz generation is especially useful for self-evaluation, allowing students to regularly test their understanding and track progress. Literature suggests that generated questions become more effective when aligned with learning objectives and subject context [8], [9].

4. Flashcards and Retrieval-Based Learning

Cognitive science research strongly supports retrieval practice as one of the most effective learning strategies. Studies show that actively recalling information leads to better long-term memory retention than passive reading or rereading [10], [11].

Digital flashcards apply this concept by presenting concise question-answer or term-definition pairs, making them ideal for quick revision sessions. This provides a strong academic basis for integrating AI-generated flashcards into modern study platforms.

5. Conversational AI for Doubt Solving

Conversational AI systems are increasingly being used for instant doubt resolution, concept explanation, and academic guidance [5], [6]. Students often benefit from receiving immediate and context-aware responses during self-study sessions.

At the same time, research emphasizes that educational chatbots should remain focused on the learning context and avoid generating irrelevant or misleading responses [7]. This supports the design of chapter-specific AI tutors that provide short, relevant, and guided explanations.

6. Practical Software Patterns in AI Study Platforms

In addition to educational value, AI-based learning systems must be technically robust and scalable. Modern web applications commonly use asynchronous job processing to handle time-consuming AI tasks while keeping the user interface responsive [1 2].

An efficient AI study platform should include:

- Asynchronous processing for content generation tasks
- Persistent storage for generated study materials
- Authentication and secure access control
- Tier-based usage limits for sustainable service delivery

7. Research Gap and Project Positioning

From the reviewed literature, many existing systems focus on only one feature, such as question generation, chatbot tutoring, summarization, or flashcards. Comparatively fewer systems provide an integrated workflow that combines multiple study tools within a single platform.

A comprehensive learning system should ideally include:

- Structured course outline generation
- Detailed chapter-wise notes
- Flashcards for memory retention
- Quiz-based self-assessment

Context-aware doubt solving support

The proposed Notes2Card project addresses this gap by integrating all these features into one web-based platform. The system focuses on practical student needs, improved study workflow, and implementation-ready architecture rather than developing a new AI model.

Study / Work	Main Contribution	Limitation Identified	Relevance to Notes2Card
Bloom (1984) [1]	Personalized tutoring improves outcomes	Not technology-specific	Supports AI-assisted personalized learning
Corbett and Anderson (1994) [2]	Knowledge tracing for adaptive learning	Domain-specific implementation	Supports adaptive study progression
VanLehn (2011) [3]	ITS effectiveness close to human tutoring	High authoring complexity	Motivates guided AI tutoring

Kasneci et al. (2023) [6]	LLM opportunities in education	Misuse and inaccuracy risks	Supports cautious AI deployment
Kurdi et al. (2020) [8]	Review of automatic question generation	Quality depends on model design	Supports quiz generation module
Karpicke and Roediger (2008) [10]	Retrieval improves retention	Requires repetition strategy	Supports flashcard learning
Ji et al. (2023) [7]	Hallucination in language models	Reliability concerns	Supports scoped prompting

III. PROBLEM STATEMENT

Students and self-learners often struggle to transform a topic into complete, revision-ready study material within limited time. In a typical learning workflow, users must manually perform multiple tasks: define a study structure, break the topic into chapters, prepare detailed notes, create flashcards for memory reinforcement, and design quizzes for self-evaluation. This process is repetitive, time-consuming, and inconsistent in quality, especially for users who lack prior planning or content-organization skills.

Existing learning tools usually address only one part of this pipeline. Some tools provide note-taking, some provide flashcards, and others provide quiz practice, but very few systems generate a connected end-to-end study flow from a single input. As a result, learners frequently switch between platforms, duplicate effort, and lose continuity in preparation.

Therefore, there is a need for an integrated system that can:

- Accept a learner's topic and study intent.
- Automatically produce structured chapter-wise study material.
- Generate multiple revision formats (notes, flashcards, quizzes) from the same content base.
- Deliver content with reliable status handling and practical usability in a real web platform.

This project addresses the above need through Notes2Card, a full-stack AI-assisted application that automates study material generation and supports both free-tier and subscription-based usage. The problem being solved is not only content generation, but also orchestration, storage, retrieval, and learner-facing accessibility of structured educational artifacts in one unified system.

Objectives

- To build an end-to-end study generation workflow that starts from user input (topic, study purpose, and difficulty level) and produces chapter-wise course structure.
- To automatically generate detailed chapter notes for each created course and store them for later retrieval.
- To generate interactive revision content, specifically flashcards and quizzes, linked to the same course context.

- To implement a modular full-stack architecture using Next.js APIs, database integration, and asynchronous job processing for scalable content generation.
- To provide secure user authentication and user-specific course management so each learner can access only their own study resources.
- To implement robust error handling and status tracking for AI-based generation tasks to improve reliability and user experience.
- To support tiered usage through free-plan limits and paid membership features with subscription management.
- To deliver a practical, production-oriented educational tool focused only on implemented functionality without unverified feature claims.

V. PROPOSED SYSTEM

The proposed system is Notes2Card, an AI-assisted, full-stack web application designed to automate study material creation from a single user input flow. Instead of requiring learners to manually prepare notes, memory cards, and tests separately, the system generates these learning assets in a connected pipeline.

The system accepts three primary inputs from the learner:

- Study purpose
- Topic
- Difficulty level

Using these inputs, the platform first generates a structured course outline containing course title, summary, and chapter-wise breakdown with key topics. After outline creation, background processing is used to generate detailed chapter notes. Additional study modes, specifically flashcards and quizzes, can then be generated for the same course to support active recall and self-evaluation.

The proposed system follows a modular architecture with the following functional blocks:

User Management Module

Handles sign-in, user identification, and user-specific access to generated courses.

Course Generation Module

Creates AI-based chapter-wise course outlines from learner input.

Notes Generation Module

Generates detailed chapter notes asynchronously and stores them with status tracking.

Study Content Module

Creates flashcards and quizzes linked to the selected course and chapters.

Content Retrieval Module

Fetches notes, flashcards, quiz data, and generation status for dashboard and course views.

Membership and Access Control Module

Enforces free-tier creation limits and unlocks higher usage through paid membership plans.

Payment Module

Handles subscription checkout, billing management, and membership lifecycle updates.

The proposed system is designed to be practical, scalable, and implementation focused. It emphasizes real delivered functionality: structured content generation, asynchronous processing, persistent storage, user-level isolation, and subscription-aware access control. This makes the platform suitable for real learner usage while providing a strong engineering foundation for future enhancements such as personalization, adaptive difficulty, and analytics-driven study recommendations.

VI. METHODOLOGY

The methodology for Notes2Card follows an implementation-driven, modular, and event-oriented software engineering approach. The system is designed as a sequence of coordinated phases, where each phase transforms user input into progressively richer study material while maintaining reliability through structured status handling.

Requirement Analysis The system was designed to solve three main issues:

- Manual effort in organizing study topics.
- Separate tools for notes, flashcards, and quizzes.
- Lack of a unified revision workflow.

Based on this, the implemented scope includes course outline generation, notes generation, flashcards, quizzes, authentication, and membership-based access.

System Design A full-stack modular architecture was selected with:

Frontend for user interaction. API layer for validation and orchestration. AI layer for content generation. Database for persistent storage. Background job system for asynchronous tasks. Payment integration for subscription handling.

Input Processing and Validation

The application collects study purpose, topic, and difficulty level. Before generation, it validates required inputs, authenticates the user, and applies server-side membership and free-tier limit checks.

Course Outline Generation

A structured prompt is sent to the AI model to generate course title, summary, and chapter-wise topics in JSON format. The response is parsed and validated before being stored in the database.

Asynchronous Notes and Study Content Generation

After course creation, background events are triggered:

- Chapter notes are generated asynchronously.
- Flashcards and quizzes are generated on demand.
- Generation status is tracked (Generating, Ready, Failed) for frontend visibility.

This improves responsiveness and avoids blocking user requests.

Storage and Retrieval The system stores user data, courses, notes, study-type content, and payment records. APIs retrieve the latest content and statuses for dashboard and course views.

Error Handling and Reliability To improve robustness, the system applies:

- AI error classification (quota, high demand, token limit, generic).
- User-friendly API error messages.
- Failure-state updates and cleanups in asynchronous workflows.

Membership and Payment Workflow The platform supports free and paid tiers:

Free users have limited course creation. Paid users get expanded access. Checkout, billing portal, and webhook updates manage subscription status securely.

Testing and Refinement

The system was iteratively tested through API flow checks, end-to-end generation validation, error-path testing, and membership-state verification, followed by prompt and workflow refinements.

VII. SYSTEM OVERVIEW

The Notes2Card system is a distributed, event-driven web application composed of a frontend layer, API gateway, external services, and a background job processor. This section describes the overall architecture, components, and how they interact to deliver study material generation.

1. Architecture Overview

The system follows a three-tier architecture pattern:

Presentation Tier (Frontend)

A Next.js-based web application that provides user interfaces for authentication, course creation, course viewing, and study content consumption. The frontend communicates exclusively through REST APIs and does not directly access the database.

Application Tier (API & Business Logic)

A set of modular API endpoints that handle request validation, user authentication checks, AI invocations, database operations, and event triggering. Each endpoint is responsible for a specific business function such as course generation, status retrieval, or payment initiation.

Data and Service Tier (Database, AI, Jobs, Payments)

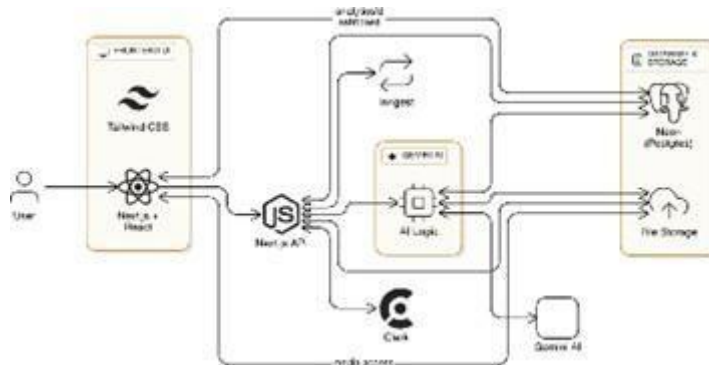

External services and persistent storage that power the backend:

- Neon PostgreSQL: Relational database for users, courses, notes, and payment records.
- Gemini API: Large language model for content generation.
- Inngest: Background job orchestration for asynchronous content generation.
- Stripe: Payment processing and subscription management.
- Clerk: Authentication and user identity.

Technology Stack

Frontend Framework	Next.js 16.0.1	Web application and API routes
Authentication	Clerk	User sign-in and session management
Database	Neon	Persistent data
	PostgreSQL	storage
AI Model	Gemini API (v3-flash)	Content generation
Background Jobs	Inngest	Asynchronous task orchestration
Payments	Stripe	Subscription and billing

The system persists the following primary entities:

Users Table

Stores user identity, email, membership flag, and Stripe customer ID.

Study Materials Table

Stores course metadata including topic, difficulty, course type (study purpose), generated chapter outline (JSON), creation timestamp, and generation status.

Chapter Notes Table

Stores HTML-formatted notes for each chapter, linked by course ID and chapter index.

Study Type Content Table

Stores flashcard or quiz content (JSON) for a course, linked by course ID, content type, and generation status.

Payment Records Table

Stores payment and upgrade history linked to the user's email and subscription session ID.

Data Flow

Course Creation Flow

- User submits topic, study purpose, and difficulty level via the frontend.
- Frontend sends POST request to /api/generate-course-outline.
- API validates input, checks user membership and free-tier limits.
- If validated, a prompt is constructed and sent to Gemini API.
- The AI-generated course outline (JSON) is parsed and stored in the database with status "Generating".
- An Inngest event is triggered to begin asynchronous note generation.
- Frontend is notified of success and redirected to the dashboard.

Notes Generation Flow (Background)

- Inngest worker receives the notes-generation event.
- For each chapter in the course outline, a detailed notes prompt is constructed.
- Gemini API generates HTML-formatted notes.
- Notes are inserted into the Chapter Notes table.
- On completion of all chapters, the course status is updated to "Ready".
- On any error, the status is updated to "Failed" and an error record is logged.

Study Content Generation Flow (Flashcards/Quiz)

- User requests flashcard or quiz generation for a course via the frontend.
- Frontend sends POST request to /api/generate-study-type-content.
- API creates a placeholder record in the Study Type Content table and triggers an Inngest event.

Inngest worker generates content using the appropriate AI prompt.

- On success, the content and status "Ready" are stored.
- On failure, the record is deleted to avoid incomplete content.

Content Retrieval Flow

- User navigates to a course view or study content page.
- Frontend sends GET/POST request to /api/study-type with the course ID.
- API fetches latest notes and study-type content from the database.
- Status flags are returned to indicate generation progress or failure.
- Frontend renders content or displays loading/failure states accordingly.

Membership and Payment Flow

- User clicks "Upgrade" on the dashboard.
- Frontend sends POST request to /api/payment/checkout.
- API creates a Stripe checkout session.
- User is redirected to Stripe payment page.
- On successful payment, Stripe sends a webhook to /api/payment/webhook.
- API updates the user's membership flag and payment record.
- User is redirected to success page and gains access to premium features.
- System Workflow Overview

The complete Notes2Card workflow is as follows:

- User Registration: Learner signs up via Clerk authentication.
- Course Planning: Learner enters a topic, study purpose, and difficulty level.
- Course Generation: System generates and stores a chapter-wise course outline.
- Background Processing: System asynchronously generates chapter notes for the course.
- Content Access: Learner views generated course outline and notes on the dashboard.
- Study Content: Learner requests flashcards or quizzes, which are generated asynchronously.
- Interactive Learning: Learner studies using notes, flashcards, and quizzes.
- Optional Upgrade: Learner can upgrade to premium membership for expanded course limits.

- Membership Management: System enforces free-tier limits and premium access based on payment status.

VIII. RESULTS

The implemented Notes2Card system was evaluated through end-to-end functional execution of its core workflows: course generation, notes generation, flashcard generation, quiz generation, user-specific content retrieval, and membership-based access control. The obtained results confirm that the platform successfully delivers integrated study content generation from a single topic of input.

1. Functional Outcomes

The key outcomes are as follows:

- The system successfully generates a structured course outline from user input (topic, study purpose, difficulty), including chapter hierarchy and topic lists.
- Chapter-wise notes are generated asynchronously and stored persistently, allowing users to access content after generation completion.
- Flashcards and quizzes are generated on demand and linked correctly to the selected course context.
- Course and study content statuses are tracked reliably (Generating, Ready, Failed), enabling proper frontend feedback during asynchronous processing.
- Free-tier usage limits are enforced on the server side, and paid membership logic works through subscription workflows.
- User-specific isolation is maintained, ensuring learners access only their own generated data.
- AI/service failure handling returns meaningful messages and avoids long-lived inconsistent states.

2. Usability Result

From a usability perspective, the system reduces manual preparation effort by combining outline creation, note preparation, recall practice, and self-assessment into one unified workflow. The dashboard and course pages provide clear progression from generation to consumption.

3. Technical Result

From a technical perspective, the event-driven approach improves responsiveness by offloading long-running generation tasks to background processing. This avoids blocking API responses and improves scalability behavior under concurrent usage.

4. Overall Result

Overall, the result demonstrates that Notes2Card is a practically working AI-assisted study platform with functional reliability, modular design, and real educational utility within the implemented scope.

IX. CONCLUSION

The Notes2Card project shows how Artificial Intelligence can be used to make student learning more organized and efficient. Instead of working as a general chatbot, the system is designed specifically for academic use. It provides a complete study flow that includes course outline generation, chapter-wise notes, flashcards for revision, quiz-based self-assessment, and doubt solving support within notes. This helps students save time and focus more on learning rather than preparing study material manually.

From the technical side, the project also demonstrates the use of a modern web development stack for building AI-based applications. Technologies such as Next.js, Clerk Authentication, Neon PostgreSQL, Drizzle ORM, Inngest, and Stripe were used to create a secure and scalable platform. The use of

background job processing improves user experience by handling time-consuming AI tasks without slowing down the interface.

The system also includes practical features such as free-tier usage limits, membership-based access control, progress tracking, and proper error handling. These additions make the project more reliable and closer to a real-world product rather than just a prototype.

Overall, Notes2Card successfully combines AI and web technologies to create a useful platform that can support students in studying, revision, and self-assessment in a smarter way.

Future Scope

The Notes2Card platform can be further improved in several ways to enhance learning experience, system intelligence, and scalability.

Personalized Learning

Future versions can generate study material based on user performance, quiz scores, and learning history. This would help students follow a customized learning path.

Smart Revision System

Flashcards and quizzes can be integrated with spaced repetition techniques to focus more on weak topics and improve long-term memory retention.

Better AI Accuracy

Future improvements may include validation checks for generated quizzes, flashcards, and notes to reduce duplicate or incorrect content.

Scalability Improvements

The system can be enhanced with better caching, queue management, and monitoring tools to handle larger numbers of users efficiently.

REFERENCES

1. B. S. Bloom, "The 2 Sigma Problem: The Search for Methods of Group Instruction as Effective as One-to-One Tutoring," *Educational Researcher*, vol. 13, no. 6, pp. 4–16, 1984.
2. K. VanLehn, "The Relative Effectiveness of Human Tutoring, Intelligent Tutoring Systems, and Other Tutoring Systems," *Educational Psychologist*, vol. 46, no. 4, pp. 197–221, 2011.
3. E. Kasneci et al., "ChatGPT for Good? On Opportunities and Challenges of Large Language Models for Education," *Learning and Individual Differences*, vol. 103, 102274, 2023.
4. OpenAI, "GPT-4 Technical Report," *arXiv:2303.08774*, 2023.
5. G. Kurdi, J. Leo, B. Parsia, U. Sattler, and S. Al-Emari, "A Systematic Review of Automatic Question Generation for Educational Purposes," *International Journal of Artificial Intelligence Research*, vol. 30, pp. 121–204, 2020.
6. J. D. Karpicke and H. L. Roediger III, "The Critical Importance of Retrieval for Learning," *Science*, vol. 319, no. 5865, pp. 966–968, 2008.
7. P. C. Brown, H. L. Roediger III, and M. A. McDaniel, *Crafting Effective Learning Experiences*. Harvard University Press, 2014.
8. Z. Ji et al., "Survey of Hallucination in Natural Language Generation," *ACM Computing Surveys*, vol. 55, no. 12, 2023.
9. S. Russell and P. Norvig, *Artificial Intelligence: A Modern Approach*, 4th ed. Pearson, 2020.
10. S. Newman, *Learning to Program*, 2nd ed. O'Reilly Media, 2021.

11. Quizlet, "Official Platform Overview and Study Tools," Accessed 2026.
12. Anki, "Spaced Repetition Flashcard Learning System," Accessed 2026.
13. Khan Academy, "AI Tutoring and Personalized Learning Resources," Accessed 2026.
14. Notion AI, "AI-Assisted Note Generation and Productivity Features," Accessed 2026.
15. OpenAI, "Educational Applications of Generative AI," Accessed 2026.