

A Review: Simulation of PV Wind based Hybrid Power System with MPPT Controllers via MATLAB

¹Ashish Kumar Kaushik, ²Ajay Barapatre

Abstract

An exercise of power effectively of renewable energy is more important in the present scenario. This paper proposes a detailed review on Hybrid power system with solar in addition with MPPT controllers. Standalone solar power system is the best choice for a rural area to supply uninterrupted power. Maximum Power Point Tracking (MPPT) is ordinarily involved in photovoltaic (PV) systems to maximize the output power from PV arrays regardless of the weather changes. Quick reaction and high tracking accuracy are two essential design requirements in MPPT control.

Keywords: Renewable energy source, Photovoltaic cell, MPPT, an Inverter, a LC filter, a distribution network, Active power, Reactive power, controller, utility grid.

Introduction

At present fossil fuels contribute as the world's major energy sources. The non-renewable nature of fossil fuel and increasing energy demand have made it scarcer than before and therefore its price is skyrocketing. On the other hand renewable energy such as wind and solar is omnipresent free and abundant in nature. Since the renewable energy technologies are improving, the electricity cost produced by renewable form is certainly going to decrease significantly in near future [1-3]. Energy crisis, ever increasing oil prices, climate changes due to greenhouse gases and limitations imposed by Kyoto protocol in production of these gases have increased people's attention towards effective, efficient [4] sustainable and almost pollution free renewable energy systems [5].

Even though renewable energy is novel, it is stochastic in nature. Its availability is sporadic and should be complemented by other power sources like batteries in most of cases [6-8]. Due to intermittent nature of the renewable energy resources, system using single renewable energy source leads to oversized components and unnecessary operational and lifecycle cost [9] Two or more forms of energy resources can be combined to

form a hybrid energy system that complements the drawbacks in each individual energy resources. Therefore, the design goals for hybrid power system are the minimization of power production cost, minimization of power purchase from grid (if it is connected to grid), reduction in emission, reduction of the total life cycle cost and increase in reliability of the power generation of system [2, 4, 8]. Integrated system of two or more renewable energy systems, also known as hybrid renewable energy system (HRES), is gaining popularity because the sources can complement each other to provide higher quality and more reliable power to customer than single source system]. A HRES can be standalone or grid connected. Standalone systems need to have generation and storage capacity large enough to handle the load. In a grid connected system, the size of storage device can be relatively smaller because deficient power can be obtained from the grid. A grid connected HRES can supply electricity to both load and the grid. However, when connected to grid, proper power electronic controllers are required to control voltage, frequency, harmonic regulations, and load sharing. Based on the type of HRES, the operating mode of HRES can be classified into remote area mode where the generated electricity is consumed locally and grid connected mode where

the renewable energy source is connected to the grid [7 - 9].

Hybrid Power System Modelling

Hybrid power system consists of three different stages: the power generation stage, converter / controller stage and the distribution stage.

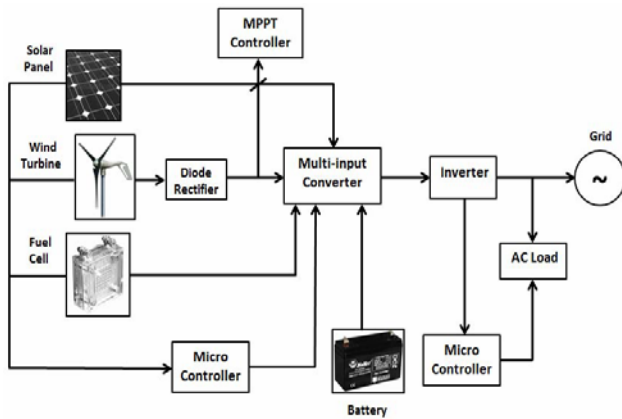

Fig.1. Block Diagram of Hybrid System

In this section, the dynamic simulation model of PV and wind turbine with PMSG is described. The developed model consists of PV array, dc/dc boost converter to achieve the desired output voltage using wind turbine, PMSG, ac/dc diode rectifier, dc/dc boost converter with MPPT. The block diagram of developed model is shown in Figure 1.

A. Modeling of PV modules in MATLAB, Simulink:

General mathematical models of PV cell were proposed by various researchers. A two-diode model of PV cell is selected whose equivalent circuit diagram is shown in Fig. 2.

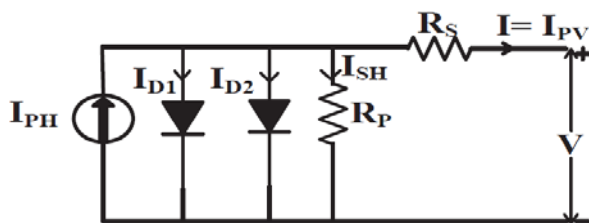

Fig. 2. Equivalent circuit of two-diode model of PV cell

The mathematical model of two-diode PV cell performance is better as compared with the numerous models of single-diode model of PV cell and also under low illumination levels, two diode model of PV cell exhibits better performance.

The two-diode PV cell shown in Fig. 2 consists of Photo-generated current (I_{ph}), two diodes with diode currents (I_{d1} , I_{d2}), Series Resistance (R_s), Shunt Resistance (R_p), output voltage (V) and PV current (I or I_{PV}). The relation between the output current and voltage can be obtained by using Kirchoff's Current Law (KCL).

$$I_{PV} = I_{PH} - I_{D1} - I_{D2} - I_{SH} \quad (1)$$

where, I_{D1} , I_{D2} are the diode currents due to diffusion;

$$I_{D1} = I_{S1} [\exp (q \cdot V / N_1 \cdot k \cdot T) - 1] \quad (2)$$

$$I_{D2} = I_{S2} [\exp (q \cdot V / N_2 \cdot k \cdot T) - 1] \quad (3)$$

where, I_{S1} , I_{S2} are the reverse saturation currents of diode D_1 , D_2 , q is the charge on electron ($1.602 \cdot 10^{-19}$ C), V is the cell output voltage, N_1 , N_2 are the quality factors of diode D_1 , D_2 , k is the Boltzmann constant ($1.38 \cdot 10^{-23}$), and T is the junction temperature. The practical PV modules have the R_s and R_p as indicated in Fig. 2. These parameters are incorporated to build the mathematical model of PV cell to replicate the practical PV cell.

$$I_{D1} = I_{S1} [e (V + R_s \cdot I / N_1 \cdot V_t) - 1] \quad (4)$$

$$I_{D2} = I_{S2} [e (V + R_s \cdot I / N_2 \cdot V_t) - 1] \quad (5)$$

where, $V_t = (N \cdot k \cdot T) / q$ is the thermal voltage of the module with N_s being number of cells connected in series, current in the shunt resistance is given by

$$I_{SH} = (V + R_s \cdot I_{PV}) / R_p \quad (6)$$

Substituting (4), (5), (6) in (1) we get the relation between the voltage and current of the two diode equivalent of the PV cell.

A number of approaches for cells and modules parameter determination can be adopted using the datasheet parameters specified by manufacturer or measured. The performance of solar cell is normally evaluated under the standard test condition, where an average solar spectrum at AM 1.5 is used, the irradiance is normalized to 1000 W/m^2 , and the cell temperature is defined as 25°C . The specifications of the solar panel listed in Table I are used and implemented in the proposed power hybrid system.

TABLE I: SPECIFICATION OF SOLAR PANEL

Specification	Value
Peak power output in voltage	700 V
Maximum power voltage	650 V
Maximum power current	14.75 A
No. and type of cell	44 cells
Working temperature	-40°C ~ 90°C

The perturbation of the output power is achieved by periodically changing (either increasing or decreasing) the controlled output power.

B. Modeling of Wind Turbine in MATLAB, Simulink:

Among various types of wind turbines, the permanent magnet synchronous generator, which has higher reliability and efficiency, is preferred in the proposed scheme. The available power of wind energy system and the mechanical power that is generated by the wind are presented as equation given:

$$P_{wind} = \frac{1}{2} (\rho A V^3)$$

$$P_m = \frac{1}{2} (\rho A V^3 C_p \lambda \beta)$$

Where, ρ is the air density (kg/m³), A is the area of the turbine blades (m²), V is the wind velocity (m/s), and C_p is the power coefficient. The power coefficient is a nonlinear function that represents the efficiency of the wind turbine to convert wind energy into mechanical energy. It depends on two variables: the tip speed ratio (TSR) and the pitch angle. The TSR (λ) refers to a ratio of the turbine angular speed over the wind speed. The pitch angle (β) refers to the angle in which the turbine blades are aligned with respect to its longitudinal axis.

The specifications of the wind turbine are listed in Table II.

TABLE II: SPECIFICATION OF WIND TURBINE

Specification	Value
---------------	-------

Rated power	2500 W
Maximum power	2250 W
Nominal voltage	650 V
Start-up wind speed	2.0 m/s
Rated wind speed	10 m/s

C. MPPT Tracking in PV System:

The characteristic of solar cell is dependent upon the insolation, temperature and array voltage. Thus it is necessary to implement MPPT in order to move the operating voltage close to maximum power point under changing atmospheric conditions. MPPT in solar is important because it reduces the solar array cost by decreasing the number of solar panels needed to obtain the desired output. V-I characteristics of the solar array neglecting the internal shunt resistance is given by;

$$I_0 = I_g - I_{sat} [\exp q(V + R_s I) / AKT - 1] \quad (7)$$

Here A is dimensionless factor.

System Control Strategy

A. The PV Side Control: The control strategy of grid connected PV inverter consists of three parts.

- i. Direct and quadrature axis current reference generator
- ii. PLL and d-q frame generation of grid voltage and current
- iii. Conversion voltage generation and PWM reference generation.
- iv. Fuzzy logic controller using for control MPPT of system.

The dc-link voltage feedback and the reference dc voltage are introduced to the $I_d - I_q$ reference generator. After making that the per unit error signal is being given to PI controller d axis reference is produced. The q axis component is being set to zero. The grid voltage and the grid current are then given to the discrete three phase PLL reference is produced and using Park's transformation current and voltage, abc are being converted to d-q-o components. From

the generated d_q current reference and the measured grid voltage and current d_q reference, the conversion voltage is calculated.

B. The Wind Turbine Power Control

To control the grid side converter we draw two inputs. One of them is the reference dc-link voltage and the other is the actual dc-link voltage. The error between the two is controlled by a PI controller .It generates the reference direct axis current of the grid side which is compared with the actual grid side direct axis current to obtain the direct axis voltage of grid side. To minimize the cross-coupling effect additional rotating compensating terms are added which finally generates the reference direct axis voltage. Similarly actual and reference quadrature axis current from the grid side are compared and controlled with the help of a PI controller which yields the quadrature axis voltage. This is added with the rotational emf compensating terms to generate the reference voltage vector of quadrature axis. Now the above mentioned references are used to generate the reference voltage vector for space vector pulse width modulation to generate the final switching signals for this converter.

- An outer dc voltage control loop is used to set the d-axis current reference for active power control. This assures that all the power coming from the rectifier is instantaneously transferred to the grid by the inverter.

- The second channel controls the reactive power by setting a q-axis current reference to a current control loop. A voltage reference is generated for the inverter that is compensated by adding rotational EMF compensation terms.

Conclusion and Discussion

Approximately one-fifth of the global populations are living without electricity in the world. In India, it is estimated that almost one third of total population are deprived of electricity. An alternative to the grid connected power is the renewable energy based off-grid power system.

Focusing on the three top most used renewable energy sources; we have presented a summary of mathematical modeling of various renewable power

systems. Non-linear characteristics of wind power system and PV system such as the power, voltage and current are summarized for maximum power point tracking. Various MPPT techniques and modeling of storage device were presented.

References

1. B. Kanagasakthivel, Dr. D. Devaraj, "Simulation and Performance Analysis of Solar PV-Wind Hybrid Energy System Using MATLAB/Simulink", IEEE transaction on power electronics, May 2015.
 2. J.O. Petrinin and Mohamed Shaaban, "A Hybrid Solar PV/Wind Energy System for Voltage Regulation in a Microgrid", Student Conference on Research and Development, IEEE Dec 2013.
 3. Jitendra Kasera, Ankit Chaplot, Jai Kumar Maherchandani, "Modeling and Simulation of Wind-PV Hybrid Power System using MATLAB/Simulink", Students Conference on Electrical, Electronics and Computer Science IEEE July 2012.
 4. Teena Jacob, Arun S, "Maximum Power Point Tracking of Hybrid PV and Wind Energy Systems Using a New Converter Topology", IEEE transaction on industrial electronics, Jan 2012.
 5. Ritesh Dash, Pratik Ranjan Behera, Dr. S.M Ali, "Hybrid System For Meeting Global Energy Demand with Solar PV And Wind System", International Conference on Control, Instrumentation, Communication and Computational Technologies (ICCICCT) IEEE Aug 2014.
 6. Pavan Kumar, Mohd. Hasan Ali, "WIND ENERGY SYSTEMS Solutions for Power Quality and Stabilization" IEEE Feb 2016.
 7. Meng Liu, Wei-Jen Lee, Lyndon K. Lee, "Wind and PV Hybrid Renewable System Dispatch using Battery Energy Storage", IEEE Oct 2013.
 8. Neethi R Nair, Mabel Ebenezer, "Operation and Control of Grid Connected Wind – PV Hybrid System", International Conference on Advances in Green Energy (ICAGE) IEEE Dec 2013.
 9. Tianpei Zhou, Wei sun, "Optimization of Wind-PV Hybrid Power System based on Interactive Multi-objective Optimization Algorithm", International Conference on Measurement, Information and Control (MIC) IEEE Sept 2012.
- Author's details**
- ¹M. Tech. Scholar, Vedika Institute of Technology, Bhopal (M.P.), India, Email: ashishkaushik120@gmail.com
- ²Asst. Professor, Department of Electronics & Telecommunication, Vedika Institute of Technology, Bhopal (M.P.), India, Email: barapatre.ajay@yahoo.co.in

Copy for Cite this Article- Ashish Kumar Kaushik, Ajay Barapatre, "A Review: Simulation of PV Wind based Hybrid Power System with MPPT Controllers via MATLAB", *International Journal of Science, Engineering and Technology*, Volume 5 Issue 2: 2017, pp. 94- 98.