

# Multi-Tank Batch Process System

Dr. Vipul Shah <sup>1</sup>, Pathik Patel <sup>2</sup>, Tanish Hande <sup>3</sup>

<sup>1</sup>Head of Department, Department of Instrumentation & Control Engineering, Dharmsinh Desai University, Nadiad, Gujarat, India.

<sup>2</sup>Student, Department of Instrumentation & Control Engineering, Dharmsinh Desai University, Nadiad, Gujarat, India

<sup>3</sup>Student, Department of Instrumentation & Control Engineering, Dharmsinh Desai University, Nadiad, Gujarat, India

**Abstract-** In small chemical industries we instrumentation people have to focus on control the temperature of on going processes and also focus on other field parameter, Temperature & Level plays very crucial role in batch chemical manufacturing industry. This research describes how we can control the level and also the main parameter Temperature, So for that we have do some research on how to make small scale project where we can learn both field devices and also about controllers. Using PLCs, we can control this batch process for live controlling and monitoring of our process, Also for real-time monitoring we use SCADA system. For industrial safety, device safety, & also for Human safety we are controlling this all field parameters and for that field device plays a crucial role, here an Instrumentation & Control Engineer monitors the process on SCADA system. And if needed than we can change the parameters values and makes it easier and safer for real-time controlling industry. Instrumentation & control engineers are not only focuses on field devices they are also responsible for safety of field devices and also controllers safety, This safety is given by an automation engineer they are also an IC people, For perfect automation we have mainly know about our application & according to that we are selecting controllers, supplies & also safety devices like MCB, RELAY, CONTACTOR, VFDs, Terminal Blocks(TB) etc.

**Keywords:** Field parameters, PLC, SCADA, Industrial Safety, Temperature & Level controlling, Safety Devices, Automation.

## I. INTRODUCTION

In small-scale chemical industries, keeping eye on process parameters is key to getting consistent quality, quantity and safety. Temperature and level—those two important parameters, especially in batch processes. If they changes too much, the whole outcome changes. Monitoring and controlling them accurately for better efficiency are crucial. It reduces material waste and keeps safety.

Automation has changed the game of whole manufacturing industries. That's days gone when people do wiring of relay logic control. Now, programmable systems like PLCs do most of the task of controlling. When you see temperature and level sensors straight to PLCs, you get pinpoint control and a whole new level of automation. SCADA systems add another layer in automation. They let

operators live data, visualize what's happening in real time, and make monitoring on single screen.

This project builds a small-scale model to demonstrate how temperature and level control really works with PLC and SCADA. It's not just about setting up the system; selection of the right sensors and safety devices is crucial for reliability. With this approach, engineers get hands-on experience with instruments and controllers, so they're ready to make industrial systems safer and more efficient.

## II. PROJECT OVERVIEW

Automation's has a huge focus in process industries, especially around temperature and level control. These two really increase or decrease product quality and safety in batch processing. Many research has prove how PLCs and SCADA systems increase efficiency and reliability.

Before PLC discovered, relay logic ruled industrial control. Problem was that it just wasn't flexible—bring loads of rewiring headaches, whenever you wanted changes. But now, PLCs have taken over. They're reliable, easy to program, and troubleshoot. Studies tells that how PLCs are perfect for batch control: they has input and output cards, run real-time commands, and handle a mix of tasks without any break.

Level control's is another big area especially in tank systems. They've shown that using level sensors and automated valves stops stuff like overflow, or losing valuable material. Multi- tank setups are everywhere for mixing, heating, and storage. People have tried both ON/OFF and more advanced techniques for keeping levels steady, but ON/OFF is easy, simple and cheap.

Temperature is Absolutely critical parameter in chemical processes. Past studies highlight temperature sensors (like RTDs and thermocouples), paired with heating elements, to keep things in the right range. When you want precise temperature control, temperature controller are used. For smaller systems, basic controls ON/OFF or PID are used to do task efficiently and fast.

The crucial part is to do communication of PLCs with SCADA. SCADA gives you live monitoring, visualizations, alarm management, —all sharp improvements for process control. Research tells that less human error, quicker calls, and smarter decisions because operators see real-time data. Plus, SCADA keeps a history so you can analyze and optimize later.

Safety doesn't take a back seat. Protective gear like MCBs, relays, contactors, and solid grounding systems keep everything safe. Engineers aren't just building for performance—they've got to stay laser-focused on safety and reliability.

Small-scale experimental setups get plenty of praise too. They're perfect for teaching and research—students and engineers actually get their hands on experience with sensors, PLC programming, and SCADA setups. The classic three-tank system with

mixing and heating. All the time as a smooth way to show batch automation in action.

So, after digging through all this, it's pretty clear: put PLC and SCADA together with solid field instruments, and you get a reliable, effective way to manage temperature and level in industrial processes. This project showing off a hands-on, straightforward model that's built for learning.

### III. OBJECTIVE

We are making these project to understand the how daily life problems are making so much trouble on our quantity of material also on quality of any product.

So to understand how we can solve this problems which are affecting daily life we are making this project & also how our Automation and Instrumentation takes place to solve all this problems.

Also what we have learned so far theoretically is useful or not is main question, so for praticle implementation also we are making this project.

For making of SCADA based project we mainly understand how SUPERVISORY CONTROL & DATA ACQUISITION

SYSTEM works , and how we can configure it with PLC (PROGRAMMABLE LOGIC CONTROLLER).

This PLCs are mainly used in small-scale Plants or Batch processes because it is a single controller and not used in continues processes or different processes.

It mainly Controls single process precisely and also works very faster as compare to other controllers. For Supervising purposes we have used a SCADA system and also for monitoring, SCADA can be also gives commands to the PLC for that we have to configure this both with each other.

We can control & monitor our process with SCADA & PLC both.

For our project we are mainly use 3 tanks, 1 for mixing our two different materials & other two are for store that two materials. For our small- scale batch process we had used a plastic tanks and three solenoid valves.

For Level Controlling we are using an float sensor which operates when our level reaches at top of its float, For temperature control we are going to use a small coffee heater which operates on 230v AC.

For temperature control we Sense our temperature using 2-wire RTD PT-100 which gives live reading of temperature to PLC.

Here my PLC reads that analog data with the help of transmitter TT7S10 it is a transmitter which reads RTDs analog data and converts it into standard form in 4-20 mA which our controller reads and based on that it gives command to our Heater.

This TT7S10 is a MASIBUS product which is made by MASIBUS to read my real life data and converts it into standard data in electrical form 4-20mA.



Figure 1: Temperature Transmitter (TT7S10)

We can configure this RTD data in Lower range as 4 mA into -200 degrees centigrade & 20 mA as 850 degrees centigrade, for this configuration of RTD one software called mTRAN is used.

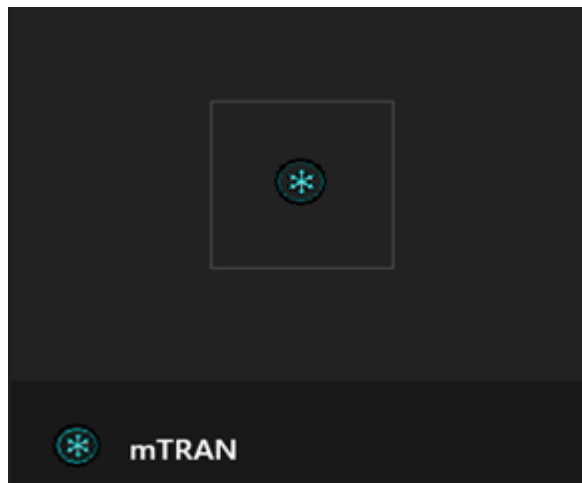

Figure 2: mTRAN Software Logo

This software is designed by MASIBUS AUTOMATION for easy configuration of temperature devices in standard form 4-20mA, 0-10V etc.

#### IV. PIPING & INSTRUMENTATION (P&ID) DIAGRAM

A Piping and Instrumentation Diagram (P&ID) is a detailed schematic used in engineering to show the piping systems, equipment, and instrumentation of a process plant.

It illustrates how process flows, control devices, valves, and instruments are interconnected and operate together.

P&IDs are essential for designing, operating, and maintaining industrial systems safely and efficiently.

## V. VISION

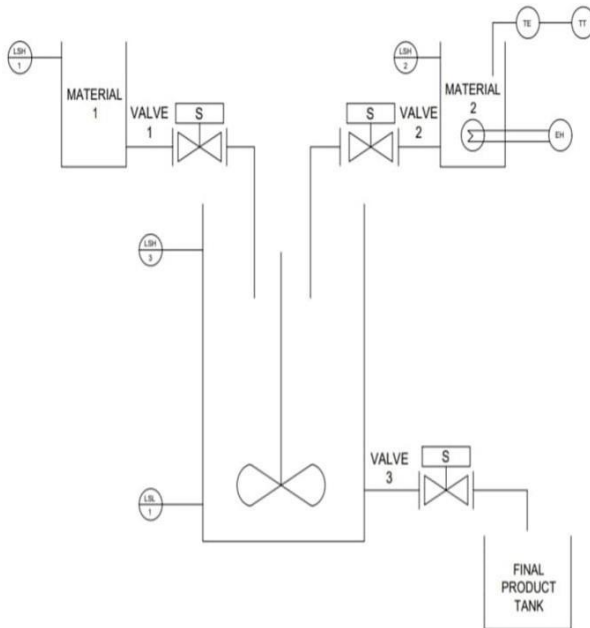

Figure 3: P&ID

The figure represents a Piping and Instrumentation Diagram (P&ID) of a mixing process involving two input streams and one output stream. Two separate feed tanks labeled Material 1 and Material 2 are equipped with level indicators and controlled valves (Valve 1 and Valve 2), which regulate the flow of materials into a central mixing vessel. The second feed line additionally includes temperature and flow-related instrumentation, indicating enhanced monitoring of that stream.

The mixing tank is fitted with a mechanical agitator to ensure proper blending of incoming materials, along with level measurement instrumentation for process control. The mixed product is discharged through Valve 3 into a final product storage tank, completing the process flow.

Overall, the diagram highlights the integration of process equipment, control valves, and instrumentation necessary for controlled mixing, monitoring, and transfer operations in an industrial system.

The vision of this project is to design and implement a practical and reliable automated system that combines thermal monitoring with a PLC and SCADA-based multi-tank batch process. The aim is to improve safety, efficiency, and ease of operation in industrial environments by continuously monitoring both process parameters and electrical conditions.

In many industrial systems, faults such as overheating develop gradually and are not easily detected by conventional protection methods. This project focuses on addressing that gap by introducing continuous temperature monitoring and integrating it with PLC logic for automatic response. The system is capable of identifying abnormal conditions at an early stage and taking necessary actions like generating alarms or controlling operations, which helps in preventing major failures.

The project also reflects a hands-on implementation of an industrial control panel. The front side of the panel includes components such as PLC, relay module, MCB, contactor, temperature transmitter, SMPS, and terminal blocks, all mounted properly on DIN rails. Push buttons are used for starting and stopping the system, while a switch is provided for manual control of specific operations. Proper wiring practices using ducts and ferrules have been followed to ensure safety and easy understanding of connections.

On the backside, the system is arranged according to process requirements with multiple tanks placed at different levels. The setup includes three valves, a motor-driven stirrer for mixing, a heater for temperature control, and float sensors for level detection. The tanks are connected using pipes and fittings, forming a complete batch processing system controlled by PLC.

SCADA integration allows the operator to monitor the entire process in real time, view system status, and analyze data. It also helps in maintaining records, identifying trends, and planning maintenance activities. Overall, the vision of this

project is to create a simple yet effective automation solution that can be applied in real industrial scenarios, improving reliability while reducing manual effort.

## VI. SYSTEM ARCHITECTURE OVERVIEW

The system architecture of this project is developed by combining field instruments, control hardware, and a supervisory monitoring system to create a fully automated multi-tank batch processing setup with thermal monitoring. The overall structure is divided into three main levels: field level, control level, and supervisory level, each performing a specific role in the operation.

At the field level, all the physical devices are installed which directly interact with the process. These include float sensors used for detecting liquid levels in tanks and a PT-100 temperature sensor connected with a temperature transmitter for measuring temperature. Along with these, solenoid valves are used to control the flow of liquid between tanks, a heater is used to maintain the required temperature, and a motor-driven stirrer is used for proper mixing. All the tanks are connected using pipelines and fittings so that the material can flow smoothly from one stage to another.



Figure 3: Field Side

The control level consists of the PLC, which works as the main controller of the system. It continuously receives signals from the sensors, such as level and temperature inputs, and processes them based on the ladder logic program. Depending on the conditions, the PLC sends output signals to operate devices like valves, relays, contactors, and the motor. It also takes decisions such as comparing the actual temperature with the set value and performing necessary actions like switching devices ON or OFF. In this way, the PLC ensures that the entire process runs automatically and in the correct sequence.

MULTI-TANK BATCH PROCESSING SYSTEM USING PLC & SCA

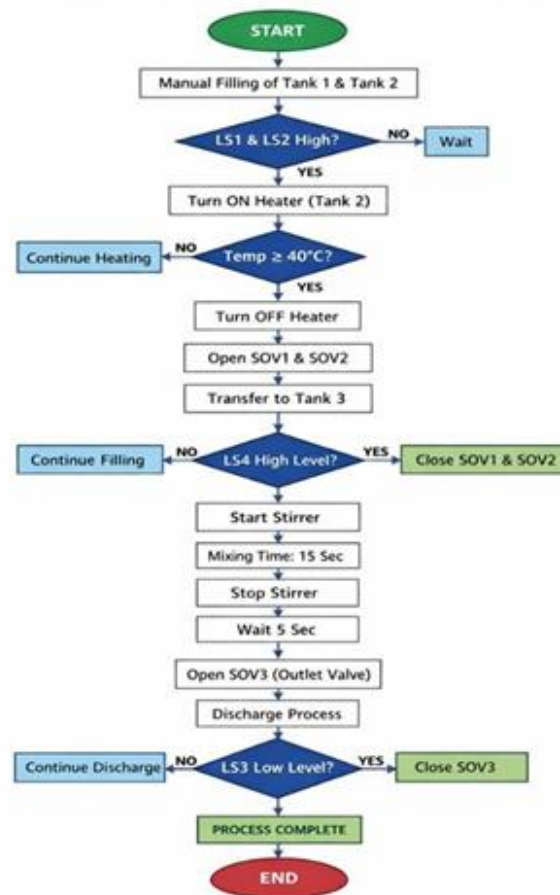

Figure 4: Flow chart

At the supervisory level, a SCADA system is used to monitor and control the process. It provides a visual interface where the operator can see the status of tanks, valves, temperature, and other parameters in real time. Through SCADA, the operator can start or

stop the system and also receive alarms if any abnormal condition occurs. In addition, SCADA stores data, which can later be used for analysis, troubleshooting, and maintenance planning.

All the control components are mounted inside an electrical panel, including the PLC, relay modules, MCB, SMPS, contactors, and terminal blocks. These components are arranged properly using DIN rails, and wiring is managed using ducts and ferrules to keep the system neat and easy to maintain.

In general, this architecture provides a clear and organized way to integrate hardware and software

for automation. It helps in achieving reliable operation, continuous monitoring, and better control of the process, making it suitable for real industrial applications.



Figure 5: SCADA HOME-PAGE



Figure 6: SCADA PROCESS PAGE

At the supervisory level, a SCADA system is used to monitor and control the process. It provides a visual interface where the operator can see the status of tanks, valves, temperature, and other parameters in

real time. Through SCADA, the operator can start or stop the system and also receive alarms if any abnormal condition occurs. In addition, SCADA stores data, which can later be used for analysis, troubleshooting, and maintenance planning.

## VII. CONCLUSION

From this project we are practically implemented everything with the back knowledge of theoretical aspects, also we have learned main thing of Automation like PLC, SCADA, Wiring connection, & Safety devices.

In instrumentation & Control Engineering, if you know your application very well then you can make your own system very precisely & with all safety concern, we can make our best quality product.

We are pleased to share that we are having a good knowledge of automation systems also we have learned other things like SCADA, Communication protocol etc.

In conclusion, we would say that we have a good hands-on experience in the automation field & also we can use safety devices for an human safety as well as for our expensive instruments safety.

## VIII. FUTURE SCOPE

The proposed SCADA-based reactor control system provides a practical solution for monitoring and controlling important parameters such as temperature and level in a small-scale batch process. However, there is still significant scope for further improvement and development.

In future work, more advanced control techniques like improved PID tuning, fuzzy logic, or model predictive control can be applied to achieve better accuracy and stability in the process. These methods can help in reducing fluctuations and improving overall system performance.

The current setup can also be expanded to a larger industrial scale. By integrating modern technologies such as the Industrial Internet of Things (IIoT), the

system can support remote monitoring and control through cloud-based platforms, allowing operators to access real-time data from any location.

Additional sensors such as pressure, flow, and pH can be incorporated to handle more complex industrial processes. Moreover, data collected from the SCADA system can be used for analysis, predictive maintenance, and early fault detection using data analytics or basic machine learning techniques.

Another important area for future development is cybersecurity, which ensures safe communication between PLC and SCADA systems. Improving the user interface of the SCADA system can also make it more user- friendly and efficient for operators.

## REFERENCES

1. Integrated Process Design and Control of a Single Reactor System  
Available:[https://www.academia.edu/6258094/2/Integrated\\_Process\\_Design\\_and\\_Control\\_of\\_a\\_Single\\_Reactor\\_System?email\\_work\\_card=thumbnail](https://www.academia.edu/6258094/2/Integrated_Process_Design_and_Control_of_a_Single_Reactor_System?email_work_card=thumbnail)
2. Integrated design and control of chemical processes – Part II  
Available:[https://www.academia.edu/9426205/9/Integrated\\_design\\_and\\_control\\_of\\_chemical\\_processes\\_Part\\_II\\_An\\_illustrative\\_example?email\\_work\\_card=thumbnail](https://www.academia.edu/9426205/9/Integrated_design_and_control_of_chemical_processes_Part_II_An_illustrative_example?email_work_card=thumbnail)
3. mTRAN Software  
Available:<https://share.google/xxx7ZuljrbGFgUtnL>
4. Aveva Plant SCADA  
Available:<https://share.google/saA9SjfTUp4XWo1y0>
5. EcoStruxure Machine Expert Basic V1.3 | Schneider Electric  
Available:<https://share.google/9QVhgVYtVao1oKE91>
6. TM200CE40U - controller M200 40 IO transistor SINK+ Ethernet | Schneider Electric India  
Available:<https://share.google/661JYtelR5ZiS1rdO>