

Novel Comparative Analysis of Hybrid Solar–Wind Powered UPFC with Advanced Control Strategies for Power Quality Enhancement and Voltage Stability Improvement in Distribution Systems

U.Surekha, R. Priyadharshini , P.Deepa

Department of EIE

St. Joseph's College of Engineering Chennai,India

Abstract- FACTS are the power electronic-based systems that provide fast and effective control of fundamental transmission characteristics like voltage, impedance, and phase angle. Hence allowing power networks to work in a far more efficient manner. The various FACTS devices directly integrated into gearbox lines improve power flow and system stability and include shunt and series compensators. One such device is the UPFC that provides full control capability by injecting the required voltage into the line through converter- based operation. Its dynamic responsiveness to voltage sags, swells, and harmonic disturbances is further refined through sophisticated control techniques such as neural- network-based modulation. The proposed approach to power quality improvement in a 230V distribution system is validated through simulation studies in MATLAB/Simulink and matching hardware implementation using renewable energy sources.

Keywords- FACTS controllers, UPFC, gearbox line compensation, voltage sag mitigation, voltage swell reduction, and harmonics suppression are some of the keywords.

I. INTRODUCTION

Electric power is the lifeblood of modern life, and the reliability and effectiveness of electrical systems depend to a great degree on the quality of that power. Power quality describes any deviation in the voltage or current from ideal levels, and directly affects the ability of loads to perform efficiently. The consequences of poor power quality include overheating of equipment, malfunctioning, demagnetization, and increased operating cost. Growing demand, along with conventional energy source depletion, threatens centralized generation with reduced efficiency as well as higher transmission costs. Distribution networks employ custom power devices to solve these problems by providing regulation of voltage, reduction of interruptions, and high quality power supply in residential and commercial applications.

II. RELATED WORK

The UPFC is an advanced FACTS device that simultaneously controls voltage, real power, reactive power, and transmission line impedance. It uses coordinated series-shunt compensation with voltage source converters to precisely control power flow. In dynamic grid situations, UPFC effectively reduces system disruptions and increases transmission efficiency.

Voltage sag, voltage swell, and voltage flicker are power quality disruptions that have a major impact on electrical equipment performance and stability. While voltage swell is a brief rise over the nominal value, voltage sag is a decrease in voltage. Rapid changes in load are what cause flicker in the lighting systems' visible light. These problems typically result from switching activities, abrupt changes in loads, or system malfunctions.

FACTS controllers, such as STATCOM, SSSC, and UPFC, use dynamic reactive power compensation and voltage regulation to counteract these disruptions. It has been keeping the voltage within reasonable bounds, which enhances stability. Transmission network efficiency and dependability. They are highly essential due to their controlled features and quick response time. In contemporary grids, nonlinear devices and load fluctuations are particularly prevalent.

Wind and solar photovoltaic systems are two instances of renewable energy sources that allow compensation methods. When combined with UPFC, the aforementioned two sources would provide clean power from the DC connection, allowing the power supply to run consistently and dependably even in the event of grid disruptions. Accurate series or shunt voltage injection is made possible by PWM-based inverter circuits and microcontroller-driven control techniques, which eventually enhance the system's overall power quality.

The entire contemporary framework for improving power quality consists of sophisticated control systems, renewable energy integration, and series-shunt compensation. MOSFET-based inverters, PWM controllers, and microcontroller-driven algorithms enable coordinated operation for real-time disturbance correction by accurately shaping injected voltages. This combination minimises losses, lowers harmonics, and guarantees the dependable operation of delicate loads in distribution systems in addition to stabilising voltage and reactive power flow.

III. METHODOLOGY

This work proposes a system integrating the UPFC with solar– wind hybrid generation to improve power quality in distribution lines. Each stage of the methodology has been divided into sensing, control, compensation, and validation steps

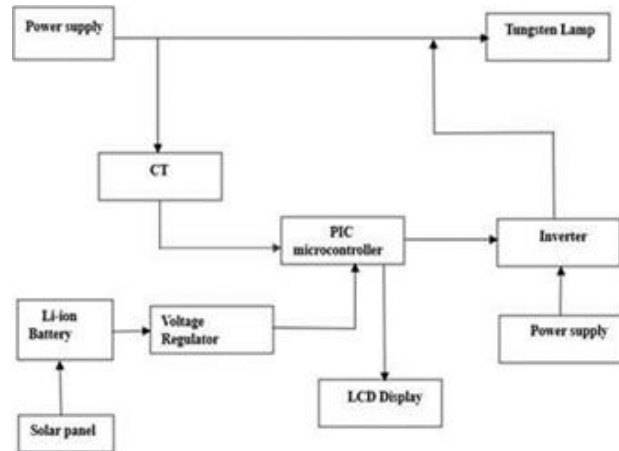

Figure shows 1 workflow of the system

A. Renewable Energy Input and DC-Link Stabilization

Photovoltaic panels generate DC power that is then conditioned by a DC to DC converter so that during all instances, proper operating voltage levels are maintained. After processing, this energy is stored in the Li-ion battery for providing uninterruptable power support. The voltage regulator ensures a stable DC-link voltage for UPFC converters. The renewable-supported DC link improves system reliability and allows compensation even during grid disturbances.

B. Measurement and Signal Acquisition

A Current Transformer (CT) and a Potential Transformer (PT) are applied for accurate real-time monitoring of the system variables. The current transformer measures transmission line current, and the potential transformer measures line voltage. These signals are conditioned and transmitted to the controller for continuous evaluation of power quality parameters like sag, swell, unbalance, and reactive power variations.

C. Controller Operation and Decision Logic

This controller receives voltage and current measurements and performs real-time computation for disturbance detection. Based on deviation from the reference values, the controller will generate gating signals by appropriate PWM techniques. These signals determine the operation of the shunt

and series converters. The controller coordinates the action through power injection, DC-link balancing, and optimization of compensation strategies.

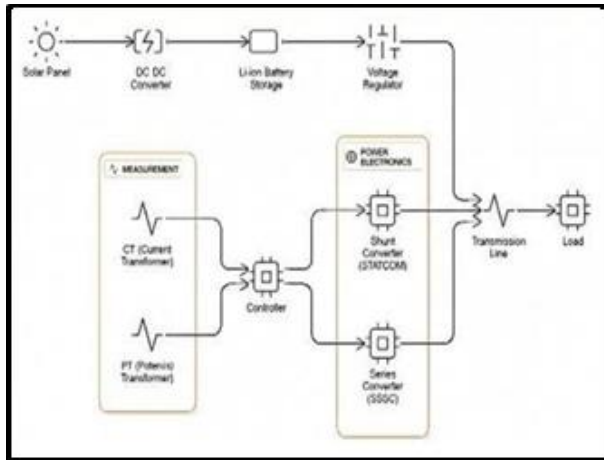

Figure shows 2 a) Renewable Energy Input and DC-Link Stabilization, b) Measurement and Signal Acquisition, c) Controller Operation and Decision Logic

D. Shunt Converter (STATCOM) Regulation

It is a shunt converter that stabilises the DC-link and keeps the system voltage constant. Reactive power is either injected or absorbed, depending on the system's requirements. The STATCOM collects excess reactive power during voltage swell and injects reactive power to increase the bus voltage during voltage dips. At the point of common coupling, reactive power balance and voltage regulation are guaranteed.

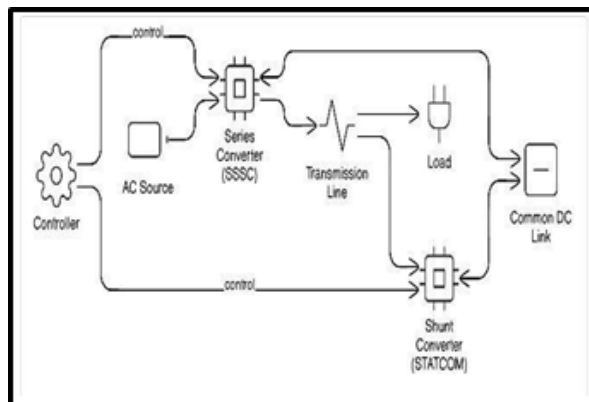

Figure shows 3 Shunt Converter Regulation

E. Series Converter (SSSC) Compensation

The series converter generates a controllable voltage in series with the transmission line to regulate real and reactive power flow. Shifting the magnitude and phase angle of the injected voltage, the SSSC compensates for sag, swell, and power oscillations. It also corrects line impedance and regulates transmitted power under dynamic loading conditions.

IV. RESULTS AND DISCUSSION

The series converter generates an adjustable voltage in series with the transmission line to regulate the flow of actual and reactive power. The SSSC corrects for sag, swell, and power oscillations by varying the injected voltage's magnitude and phase angle. Additionally, it controls transmitted power under dynamic loading circumstances and adjusts line impedance

4.1 UPFC Experimental Hardware

The physical arrangement represents the implementation of the concept of UPFC, by associating control and power stages. A basic system consists of:

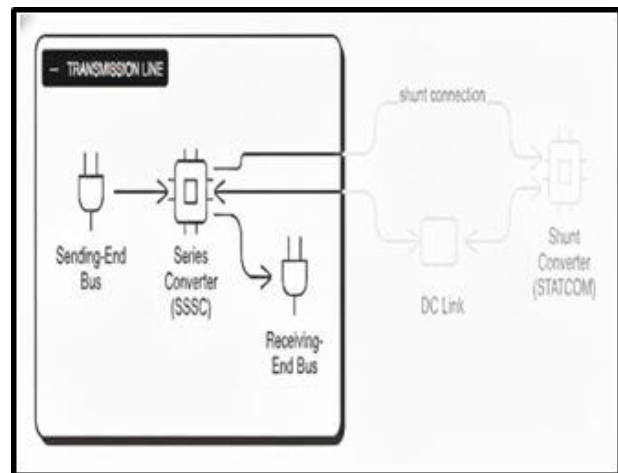

Figure shows 4 Series Converter (SSSC) Compensation

F. Coordinated UPFC Operation

The power exchange is bidirectional because both converters share a DC link. The coordinated operation of SSSC and STATCOM allows for independent control of both reactive and active

power. This unified control will improve power flow stability, lower losses, and ease power quality issues brought on by flicker, harmonics, and voltage fluctuations

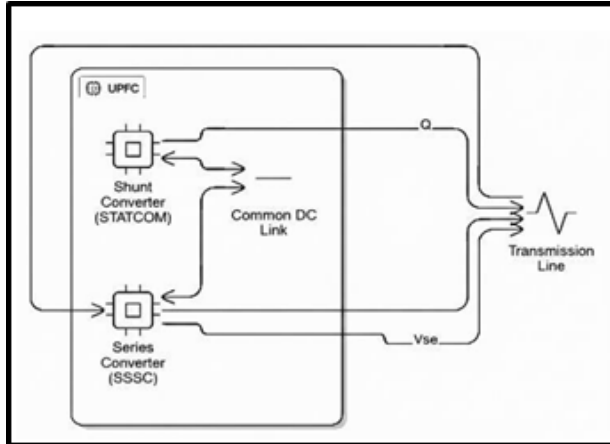

Figure shows 5 Coordinated UPFC Operation

G. Power Quality Enhancement at Load End

The combined effect of series and shunt compensation ensures that the load receives a stable and distortion-free supply. The methodology effectively eliminates sag/swell conditions, reduces voltage fluctuations, and supports dynamic load variations. The overall quality, reliability, and efficiency of the transmission line thereby receive a great boost.

- A Control and Display Unit (Top-Left PCB) housing the microcontroller and LCD for high-speed processing of control algorithms, such as d-
- q axis transformations, and system monitoring.
- Bottom-Left PCB: Gate Driver Circuits providing isolated switching signals to the power modules.
- The architecture consists of two Brown PCBs, representing the VSC Power Stages which implement the shunt and series compensation units, and are coupled to the AC line via Coupling Transformers-yellow components. This allows independent control of shunt current injection (for harmonics) and series voltage injection (for transients).

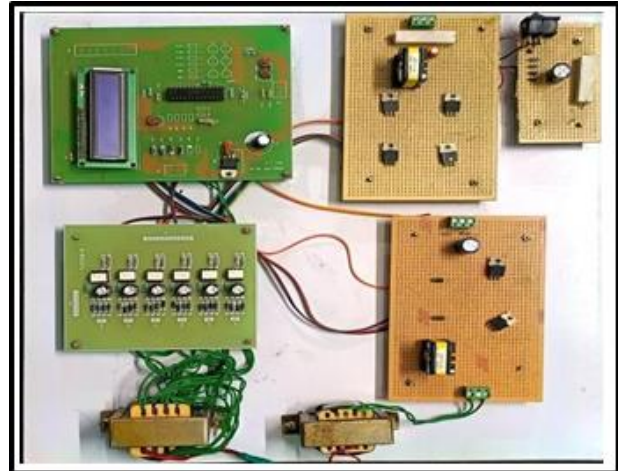

Figure shows 6: UPFC Hardware Implementation

4.2 Transient Voltage Compensation

The dynamic response of the UPFC to induced voltage disturbances brings out the effectiveness of its series compensation capability.

4.3 Harmonic Distortion Mitigation

Harmonic spectrum analysis is used to evaluate the UPFC's performance as an Active Power Filter (APF) through its shunt VSC.



Figure shows 7a Voltage Sag – Before and After Compensation

- Observation: The uncompensated system (Orange trace) has a major voltage sag, and the voltage magnitude decreases to 0.60 p.u.
- Mitigation: The compensated system (Blue trace) exhibits a prompt and effective action, keeping the load voltage at the nominal 1.0 p.u. during the entire disturbance period. The instantaneous recovery time shows the high dynamic range

and speed of response of the series VSC in injecting the missing voltage component to completely restore the line voltage magnitude.

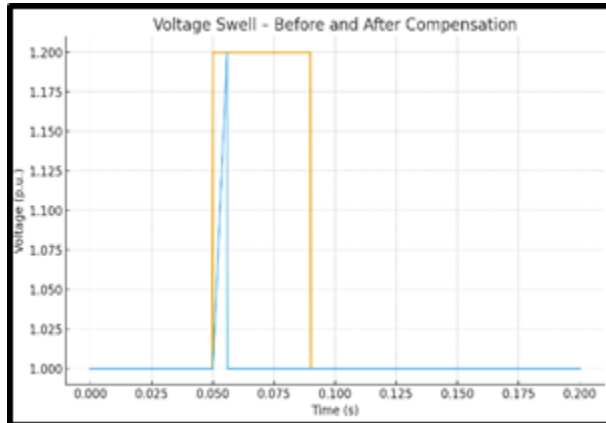

Figures shows 7b Voltage Swell – Before and After Compensation

- Observation: In the uncompensated case, source voltage swells briefly to 1.20 p.u.(Orange trace).
- Mitigation: The UPFC instantaneously opposes the swell by injecting a voltage against the overvoltage; this regulates the load voltage back to \$1.0\$ p.u.
- Discussion: The UPFC's series component's strong voltage regulation capability, which is essential for shielding delicate loads from damaging voltage changes, is confirmed by the symmetric performance in balancing both the sag and swell circumstances.

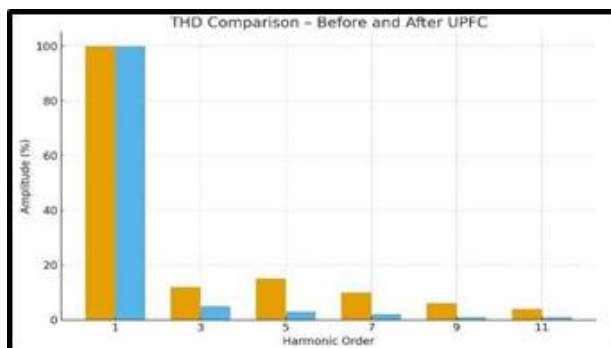

Figure shows 8 THD Comparison – Before and After UPFC

- Observation: Lower-order odd harmonics (3rd, 5th, 7th, 9th, and 11th) exhibit significant amplitudes in the uncompensated system. For instance, the amplitude of the fifth harmonic is roughly 15%.
- Mitigation: All observed harmonic amplitudes are significantly decreased after UPFC deployment (blue bars). For example, the fifth harmonic is decreased to about 3%. The Total Harmonic Distortion (THD) is significantly reduced as a result of this notable reduction throughout the spectrum.
- Discussion: The control strategy's ability to precisely extract harmonic components and instruct the shunt VSC to inject precise, compensating harmonic currents is validated by the successful harmonic attenuation, which brings the power system closer to compliance with international standards (such as IEEE 519).

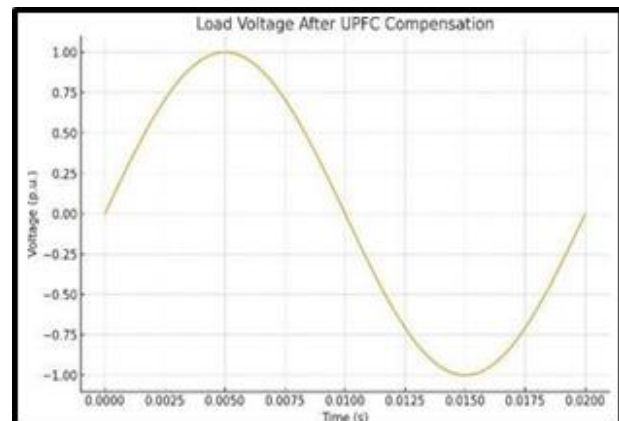

Figure shows 9 Load Voltage After UPFC Compensation

A pure, undistorted sinusoid with a peak magnitude of 1.0p.u. is the final voltage waveform provided to the load. This is unmistakable evidence that the UPFC has achieved its objective of supplying regulated, high-quality power while concurrently reducing both transient and steady-state power quality problems.

V. CONCLUSION & FUTURE WORK

In a contemporary electrical distribution network, the controller system successfully demonstrates its capacity to enhance the overall power quality. The

system provides dependable and dynamic correction under changing grid conditions by combining solar photovoltaic generation, battery-supported DC-link stabilization, accurate CT/PT measuring units, and coordinated control of series and shunt converters. The shunt converter effectively performs active harmonic filtering and reactive power compensation, lowering the Total Harmonic Distortion from around 15% in the uncompensated system to about 3% following compensation. This produces a smoother, virtually sinusoidal load voltage waveform.

In addition, the series converter maintains the load voltage at the nominal 1.0 p.u. In both sagging and swelling circumstances. By minimising voltage-related failures and maintaining the continuous operation of sensitive loads, this dual compensation capacity enhances the power system's stability and efficiency. Better use of the transmission network and independent control over active and reactive power flows are made possible by coordinated operation of the STATCOM and SSSC over a shared DC link. Incorporating renewable energy not only guarantees a steady DC supply for the converters but also improves sustainability by lowering reliance on outside grid power during disruptions. Overall, the findings confirm that the suggested UPFC design is a reliable, adaptable, and extremely efficient FACTS-based system that can satisfy demanding power quality standards and provide a scalable route for upcoming distributed energy and smart grid applications.

REFERENCES

1. L. Gyugyi, C. D. Schauder, S. L. Williams, T. R. Rietman, D. R. Torgerson, and A. Edris, "The Unified Power Flow Controller: A New Approach to Power Transmission Control," *IEEE Transactions on Power Delivery*, vol. 10, no. 2, pp. 1085–1097, Apr. 1995.
2. N. G. Hingorani and L. Gyugyi, *Understanding FACTS: Concepts and Technology of Flexible AC Transmission Systems*, New York, NY, USA: IEEE Press, 2000.
3. M. Noroozian, L. Angquist, M. Ghandhari, and G. Andersson, "Use of UPFC for Optimal Power Flow Control," *IEEE Transactions on Power Delivery*, vol. 12, no. 4, pp. 1629–1634, Oct. 1997.
4. R. Natesan and G. Radman, "Effects of STATCOM, SSSC and UPFC on Voltage Stability," *IEEE Transactions on Power Systems*, vol. 19, no. 1, pp. 546–550, Feb. 2004.
5. S. Mishra, "Neural-Network-Based Adaptive UPFC for Improving Transient Stability Performance of Power System," *IEEE Transactions on Neural Networks*, vol. 17, no. 2, pp. 461–470, Mar. 2006.
6. C. D. Schauder and H. Mehta, "Vector Analysis and Control of Advanced Static VAR Compensators," *IEEE Proceedings – Generation, Transmission and Distribution*, vol. 140, no. 4, pp. 299–306, Jul. 1993.
7. C. Collins, N. Watson, and A. Wood, "UPFC Modeling in the Harmonic Domain," *IEEE Transactions on Power Delivery*, vol. 21, no. 2, pp. 933–938, Apr. 2006.
8. S. Bhowmick and B. N. Kumar, "An Indirect UPFC Model to Enhance Reusability of Newton Power-Flow Codes," *IEEE Transactions on Power Delivery*, vol. 23, no. 4, pp. 2079–2088, Oct. 2008.
9. V. Milanović and Y. Zhang, "Global Minimization of Financial Losses Due to Voltage Sags with FACTS-Based Devices," *IEEE Transactions on Power Delivery*, vol. 25, no. 1, pp. 298–306, Jan. 2010.
10. G. Shahgholian, P. Shafaghi, S. Moalem, and M. Mahdavian, "Damping Power System Oscillations Using STATCOM in Single-Machine Infinite-Bus Systems," in *Proc. IEEE Int. Conf. on Electrical and Electronics Engineering*, Dec. 2009, pp. 130–134.
11. B. Chen, W. Fei, C. Tian, and J. Yuan, "Research on an Improved Hybrid Unified Power Flow Controller," *IEEE Transactions on Industry Applications*, vol. 54, no. 6, pp. 5649–5660, Dec. 2018.
12. E. Acha, C. R. Fuerte-Esquivel, H. Ambriz-Pérez, and C. Angeles-Camacho, *FACTS: Modelling and*

Simulation in Power Networks,Chichester, U.K.:
Wiley, 2004.

13. A. Rajabi-Ghahnavieh and M. Fotuhi-Firuzabad,
"UPFC for Enhancing Power System
Reliability,"IEEE Transactions on Power Systems,
vol. 25, no. 1, pp. 288–296, Feb. 2010.
14. L. Chen, G. Wang, and Y. Xu,"Power Quality
Enhancement Using Unified Power Flow
Controller,"
IEEE Transactions on Power Delivery, vol. 24, no.
4, pp. 2159– 2167, Oct. 2009.
15. H. Fujita and H. Akagi,"The Unified Power Quality
Conditioner: The Integration of Series- and
Shunt-Active Filters,"IEEE Transactions on Power
Electronics, vol. 13, no. 2,pp. 315–322, Mar. 1998.