

On-Road Emission Analyzer With Certification System

Mrs.Samundeeswari A, Mr.Kayakakula Saikrishna, Mr.Lingeshwaran V, Mr. Mohan S, Mr.Samraj Sami Durai

Ece, Paavai Engineering College

Abstract— The project on-road emission analyzer designed to measure real-time exhaust pollutants from moving vehicles using high-precision gas sensors. The system captures key gases such as CO, CO₂, HC, and NO_x with improved accuracy through an embedded microcontroller-based data acquisition unit. A wireless communication module transfers the collected data to a central monitoring platform for further analysis. The device enables quick, non-intrusive testing of vehicles under real driving conditions, unlike traditional stationary emission tests. Advanced algorithms validate the measured values against pollution control norms to determine compliance. If the vehicle meets the standards, the system automatically generates a digital emission certificate.

Keywords- For this project include on-road emission analyzer, real-time vehicle monitoring, exhaust gas detection, CO, CO₂, HC, NO_x measurement, gas sensors, embedded microcontroller, wireless data transmission, pollution control norms, emission compliance, digital emission certificate, and smart environmental monitoring.

I. INTRODUCTION

In the modern era of industrialization and rapid urban development, vehicular emissions have become one of the leading causes of environmental pollution. The increasing number of automobiles has contributed significantly to the degradation of air quality, especially in metropolitan areas. The pollutants emitted by vehicles—such as Carbon Monoxide (CO), Hydrocarbons (HC), Nitrogen Oxides (NO_x), and Particulate Matter (PM)—are harmful not only to human health but also to the global ecosystem. In this context, it becomes essential to develop efficient, accurate, and low-cost emission analyzing systems to monitor and control vehicular pollution. The project titled "On-Road Emission Analyzer with Certification System" addresses this issue by providing a smart, automated, and economical solution for exhaust emission measurement. The system employs an embedded micro-controller (PIC16F877A) for real-time processing of sensor data and integrates optical sensing technology based on the Beer-Lambert Law to analyze the concentration of pollutants in vehicle

exhaust gases. Unlike traditional manual testing setups, this project automates the entire testing process—from gas detection to result generation and certification—ensuring speed, reliability, and precision. This system aims to provide an innovative and practical alternative to conventional emission testing devices that are often bulky, expensive, and time-consuming.

By using low-cost components and efficient embedded programming, this project contributes toward affordable and accessible pollution control technology suitable for both small-scale testing stations and large-scale regulatory applications.

II. METHODOLOGY

The system is an IoT-based on-road emission monitoring and certification system designed to measure, analyze, and record vehicle exhaust emissions in real time while vehicles are in motion. The system aims to automate the process of pollution checking and certification, replacing the traditional manual emission testing centers with an intelligent, portable, and continuous monitoring approach.

In this system, each vehicle's exhaust gases such as CO (Carbon Monoxide), CO₂ (Carbon Dioxide), and HC (Hydrocarbons) are detected using infrared gas sensors and gas concentration sensors installed near the vehicle exhaust or in roadside analyzer units. The detected signals are processed by a microcontroller (e.g., PIC16F877A or Arduino), which converts sensor data into digital form and analyzes pollutant levels. The system then compares these measured values with the permissible limits defined by the pollution control board or Bharat Stage (BS) emission standards. If the readings exceed the threshold, the system automatically generates a pollution alert and records the vehicle details.

Vehicle identification is performed using RFID technology, license plate recognition, or a unique vehicle ID transmitted through an IoT module. The data, including emission levels, vehicle number, and status (pass/fail), are transmitted to a cloud database or central monitoring server using Wi-Fi or GSM communication. The stored data can be accessed by transport authorities and pollution control boards through a web or mobile interface for verification and certification. Vehicles that comply with the emission standards automatically receive a digital pollution certificate, while non-compliant vehicles are notified for maintenance or penalization.

This system promotes real-time, paperless, and automated emission certification and ensures continuous tracking of pollution levels on public roads. It supports environmental sustainability by enabling authorities to identify high-emission vehicles instantly and take corrective actions to reduce urban air pollution.

Once a valid pressure signal is detected, the microcontroller triggers specific outputs such as switching on or off electrical devices using relays and drivers. The system can also communicate with a computer through an RS232 interface for data logging or further processing. This methodology ensures

smooth, safe, and responsive operation, enabling physically challenged users to perform essential tasks independently with minimal effort.

3.1.2 Block Diagram

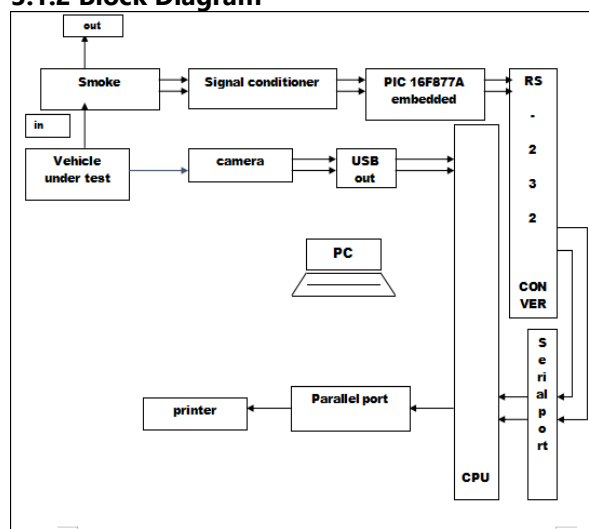

Figure 3.1 Block Diagram

The project aims at making the exhaust gas testing process fully automated and hence to be more effective with respect to the real time. The project also aims at design of the pollution analyzer for costs, which are considerably cheaper. We follow the principle of BEER LAMBERT LAW to analyze the amount of carbon monoxide from the exhaust of the vehicle.

The test is monitored using the computer. The computer is used to analyze the test and produce the output. The output is produced along with the graph and photo of the vehicle. This makes the project user friendly and simpler to work with.

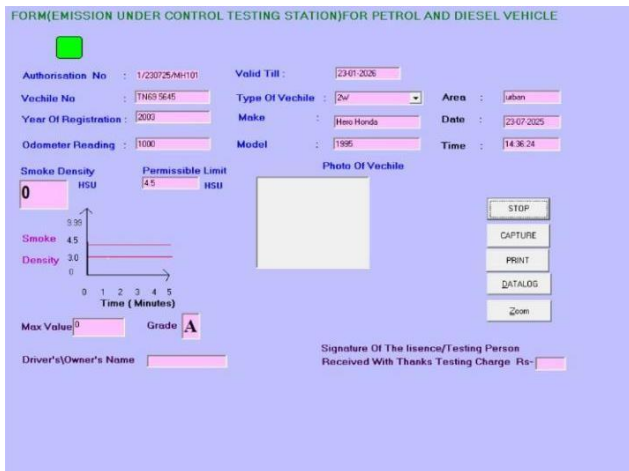

Figure 3.1 Simulation output

This output form serves as an automated pollution certificate, containing all relevant vehicle and emission details. It ensures accuracy, transparency, and digital record-keeping, replacing manual pollution testing methods. The combination of sensor data, micro controller processing, and PC-based software makes the entire emission testing process efficient and user-friendly.

This are the following data that has been included in the simulation output:

Vehicle No., Type of Vehicle, Manufacturer and specific model year, Year of Registration., Date / Time of Test, Authorization No., Valid Till.

III. RESULTS AND DISCUSSION

The fully automated model we have made to analyze the pollution of the vehicle is the foolproof system to over come the disadvantage of the previous model. We have written the software in the visual basic, which is very simple. By interfacing our kit with the computer we can display the result of the pollution test conducted with respect to the real time. Thus, we have built a model, which could be a perfect solution for the problems existing with the present system, at costs, which are considerably cheaper for all the characteristics it possesses.

The proposed system was tested under various vehicle conditions to evaluate its effectiveness in detecting and responding to abnormal emissions. The results demonstrate the system’s capability to monitor CO₂ levels accurately and initiate appropriate alerts and actions.

Sensor Readings

Gas	Petrol	Diesel
CO(Carbon Monoxide)	5000ppm	3000ppm
HC(Hydrocarbons)	200ppm	50ppm
CO ₂ (Carbon Dioxide)	10000ppm	15000ppm
NO _x (Nitrogen Oxides)	1500ppm	1000ppm
O ₂ (Oxygen)	3000ppm	12000ppm
PM(Particulate Matter)	300ppm	100ppm
SO ₂ (Sulphur Dioxide)	500ppm	50ppm

Figure 2.10.3 Amount of each Gas

These readings confirm that the sensor can reliably distinguish between compliant and non-compliant emission levels.

Normal Operation: The system continuously monitors emissions and displays real-time data on the LCD. No alerts are triggered, and the vehicle operates normally. Abnormal Emission: When emissions exceed the threshold, the system displays a warning, starts a countdown timer, and sends alerts to RTO and CPCB. Fig. 5 and Fig. 7 show the warning interface and the message received by authorities, respectively. FC Expiry Detection: The system also monitors the vehicle’s Fitness Certificate status. If expired, it sends a separate alert to the RTO. The ECU responds to abnormal emissions by disabling the spark plug, effectively shutting down the engine. This enforcement mechanism ensures that polluting vehicles are taken off

the road until serviced. The GSM and GPS modules successfully transmitted alerts and location data. The messages included vehicle ID, emission level, and coordinates, enabling swift action by authorities.

Overall, the results validate the system's functionality and reliability. It provides a real-time, automated solution for emission monitoring and enforcement, contributing to cleaner urban environments.

IV. CONCLUSION

Here we conclude that the fully automated model we have made to analyze the pollution of the vehicle is the foolproof system to overcome the disadvantage of the previous model. We have written the software in the visual basic, which is very simple. The automation process suggested involves web camera, which adds some real time impact to our project. In future with the evolution of electronic number, plate replaces the use of web camera in the testing process. Here, in this prototype model we can include more number of features depending on the improvement of the corporation system. We can include more sensors to detect the amount of other pollutants present in the exhaust gas of the vehicle. This will include to more circuits that are complicated and there are chances for misreading.

It is possible to write advanced programs, which would make the model more users friendly. We can also write software, which could give voice output so that it would be very easy for the user to know the amount of pollutant and the result of the test. Hence, with the fast growing field of science and technology it is possible to improve our model to the greater extent of user friendliness. By interfacing our kit with the computer we can display the result of the pollution test conducted with respect to the real time. Thus, we have built a model, which could be a perfect solution for the problems existing with the present system, at costs, which are considerably cheaper for all the characteristics it possesses

Acknowledgement

The authors gratefully acknowledge the Paavai Engineering College, Namakkal, India for providing the laboratory infrastructure and technical support required to carry out this research work.

REFERENCES

1. Y. Huang et al., "Rapid detection of high-emitting vehicles by on-road remote sensing technology improves urban air quality," *Science Advances*, Feb. 2022.
2. B. Giechaskiel, V. Valverde, and M. Clairotte, "Real Driving Emissions (RDE): 2020 assessment of Portable Emissions Measurement Systems (PEMS) measurement uncertainty," EUR 30591 EN, Publications Office of the European Union, Luxembourg, 2021.
3. A. Narla, A. Deo, B. Sathiamoorthy, and T. Dallmann, "Real-driving emissions from Bharat Stage VI (phase 1) passenger cars and a light commercial vehicle in India – PEMS testing," Working Paper, International Council on Clean Transportation, July 2024.
4. Narla, Y. Bernard, T. Dallmann, and A. Bhatt, "Real-world motor vehicle exhaust emissions in Delhi and Gurugram using remote sensing," *The Real Urban Emissions (TRUE) Initiative & ICCT*.
5. S. Meena and S. K. Singh, "Assessment of real driving emissions from vehicles using portable emission measurement systems: A systematic review," *Appl. Ecol. Environ. Science* 2022.
6. M. Mądział, "Investigating real-world emissions from liquefied petroleum gas-fueled vehicles: A modeling approach that utilizes portable emissions measurement systems," *Open Transp. J.*, 2025.
7. A. Kochanek, J. Janczura, S. Jurkowski, T. Załona, and P. Kwaśnicki, "The analysis of exhaust composition serves as the foundation of sustainable road transport development in the context of meeting emission standards," *Sustainability*, 2025.
8. O. Farrag, A. Mansour, B. Abed, A. Abu Alhaj, T. Landolsi, and A. R. Al-Ali, "IVEMPS: IoT-based

- vehicle emission monitoring and prediction system," IEEE Access, 2025.
9. K. Laya, B. Sravan Kumar, E. Balakrishna, and N. Satyavathi, "CO₂ emission rating by vehicle using data science," Industrial Engineering Journal, Sept. 2024
 10. P. A. Mozhi Devan, F. A. Hussin, R. Ibrahim, K. Bingi, and M. Nagarajapandian, "IoT based vehicle emission monitoring and alerting system," in Proc. IEEE Student Conf. Research and Development (SCORed), Seri Iskandar, Malaysia, Oct. 2019.